

**A SECTION**

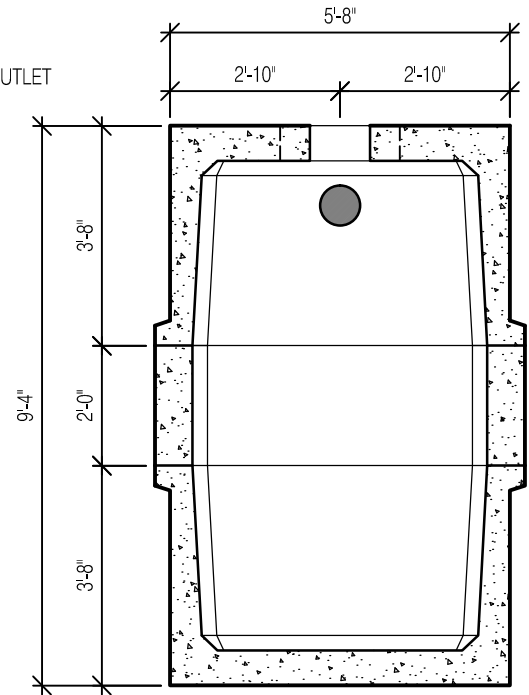

**B SECTION**

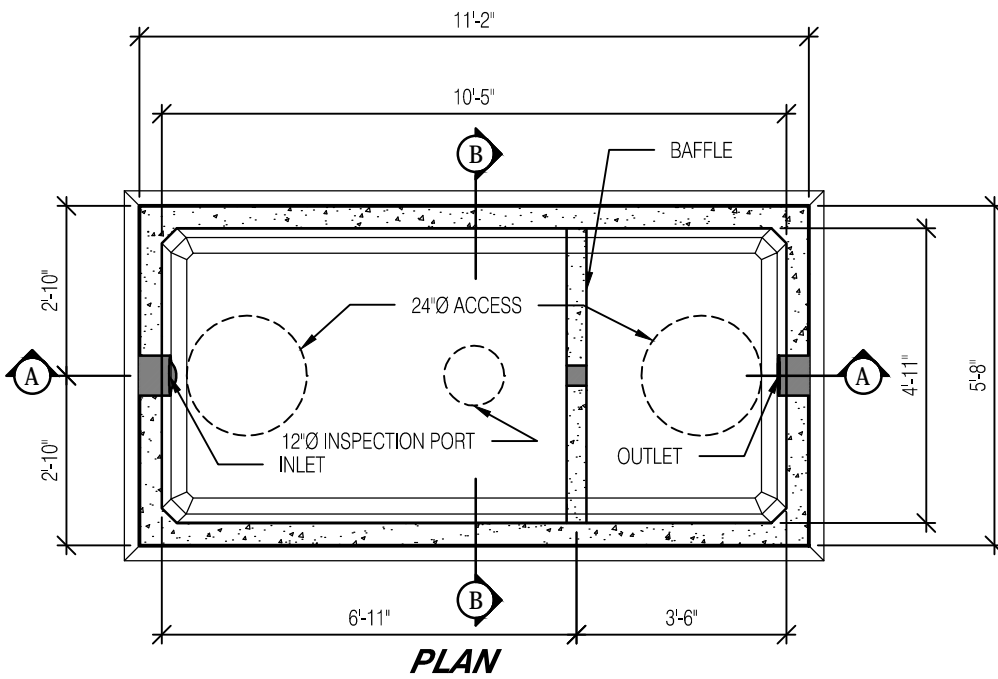

**PLAN**

**GENERAL NOTES:**  
 \*2500 GALLON CAPACITY BASED UPON 90" WATER LEVEL.  
 - EXACT CAPACITY DEPENDANT UPON SIZE AND LOCATION.  
 \*\* ACCESS HATCH PER SPECIFICATION AND LID CONFIGURATION DEPENDANT UPON REQUIREMENTS.