

ECCENTRIC CONE
 2,250 LBS

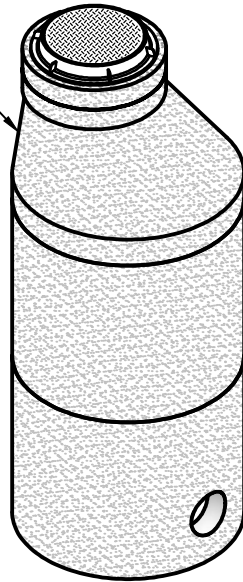

GASKET

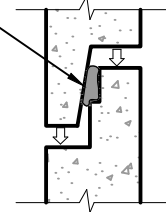

1 DETAIL

ADJUSTING RISERS (AS REQ'D.)

	"H"	WEIGHT
MAR24-2	2"	75 LBS
MAR24-4	4"	150 LBS
MAR24-6	6"	230 LBS

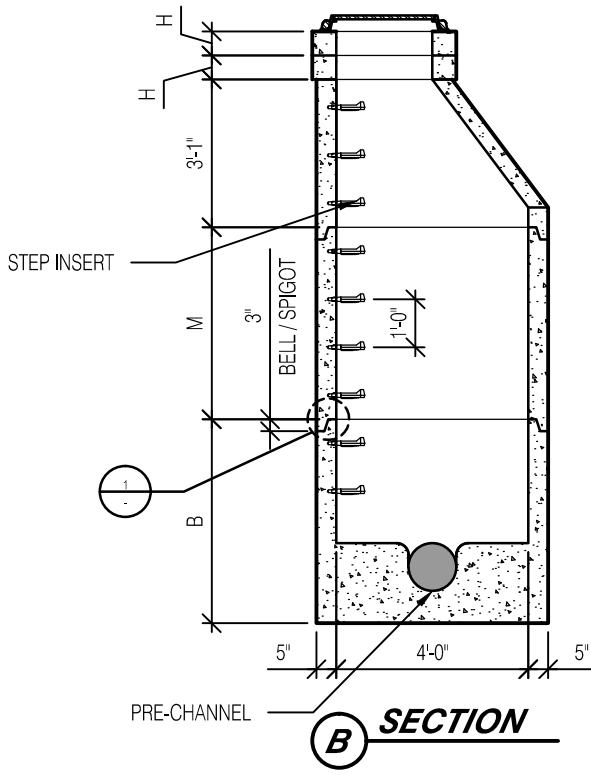
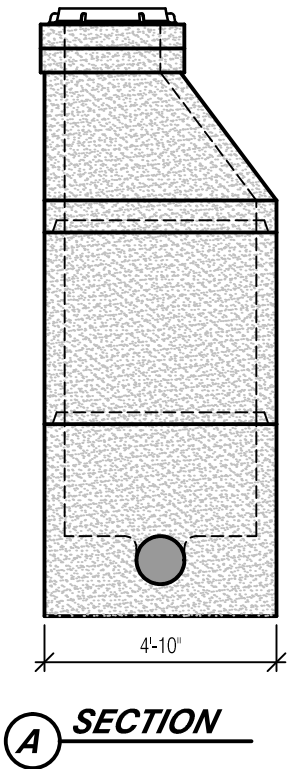

RISERS

	"M"	WEIGHT
MH48-1	12"	850 LBS
MH48-2	24"	1,700 LBS
MH48-3	36"	2,500 LBS
MH48-4	48"	3,350 LBS

BASE SECTION

	"B"	WEIGHT
MH48X2B	24"	4,100 LBS
MH48X3B	36"	4,950 LBS
MH48X4B	48"	5,800 LBS

NOTES:

1. MANHOLE ASSEMBLY CONFORMS TO ASTM-C478/W.S.D.O.T./A.P.W.A. STANDARD SPECIFICATIONS
2. ALL MANHOLE JOINTS SEALED WITH MASTIC OR RUBBER GASKET
3. REINFORCING AS PER WSDOT STANDARD PLAN

S
A
N
I
T
A
R
Y
S
E
W
E
R